

Warewashing
Small Double Skin GW, electronic, cold
rinse, water softener & rinse aid
dispenser, 30b/h

ITEM # _____

MODEL # _____

NAME # _____

SIS # _____

AIA # _____

402217 (ESICW)

Glasswasher (small), with double skin, electronic control, cold rinse, built-in water softener and rinse aid dispenser, 3 cycles, 30b/h

Short Form Specification

Item No. _____

Unit shall be Electrolux Professional green&clean Glasswasher type hot water rinsing using rack dimension of 400*400mm. Electrical characteristics to be 230 volts single phase 50Hz operation. Washing performance is ensured by a powerful wash pump, revolving washing spray arms both from bottom and top. Rinse temperature and pressure guaranteed by built in pressure boiler. Three automatic cycles of 120/300/120 seconds suitable for glasses and small plates/ saucer. Third cycle having cold rinse after hot rinse phase provides hygiene glasses and cold enough to handle. Double skin counter-balance door. Large door opening of 290mm for washing tall glasses. Double skin cabinet. Pressed tank with round corners. 304 stainless steel construction to include door, frame, wash tank, tank filter, wash arms and rinse arms. Electronic control with temperature display. The unit shall include water softener and rinse aid dispenser pump and is equipped with electric cable and Schuko plug.

Main Features

- Built-in rinse aid dispenser with automatic initial and continuous cycle loading for perfect result while minimizing service and maintenance needs.
- Low noise level.
- Built-in pressure boiler designed to raise incoming water to a guaranteed minimum temperature of 82° C for sanitizing rinse. No external boiler is required.
- Maximum capacity of 30 racks per hour.
- Equipped with single phase electrical cable and Schuko plug for easy and fast installation.
- Washing system endowed with rotating washing arms from both top and bottom, high powered wash pump and large capacity wash tank guarantee professional washing.
- Easy service access to main components without moving the unit.
- Optional rinse booster pump available to be installed on site.
- Incorporated Soft Start feature to offer additional protection to more delicate items.
- Extra program to cold rinse beer and wine glasses providing sanitized glasses, cool enough to handle.
- Equipped with water softener to ensure optimal rinsing results.
- New electronic control panel for easy setup of the working parameters and self diagnosis.
- 120/300/120 seconds cycle, the third cycle includes cold rinse.

Construction

- Completely closed on the back by a cover plate.
- Unit to feature rinse aid dispenser pump.
- Wash/rinse arms and nozzles in stainless steel.
- Finished in top quality stainless steel with double skinned construction to aid durability and reduce noise.
- Internal components (arms and filter) are easy extractable.
- Large tank filter collects the soil to keep the wash water clean for a longer time and have better washing performance.
- Deep drawn pressed wash tank with fully rounded corners, sloped towards the drain to prevent dirt buildup, provides fast drainage in just a few minutes. With no welding points the pressed tank offers a guaranteed water tight solution.
- 304 AISI stainless steel front panel, load bearing frame, wash tank, tank filter, wash and rinse arms.

Sustainability

- Insulated double skin door construction preserves heat inside the tank to lower energy consumption and the noise. Counter-balance mechanism minimizes impact when opening and closing.



APPROVAL: _____

Included Accessories

- 1 of Stainless steel tank filter PNC 864003
- 1 of Square basket for glasses 400x400x150mm PNC 864470

Optional Accessories

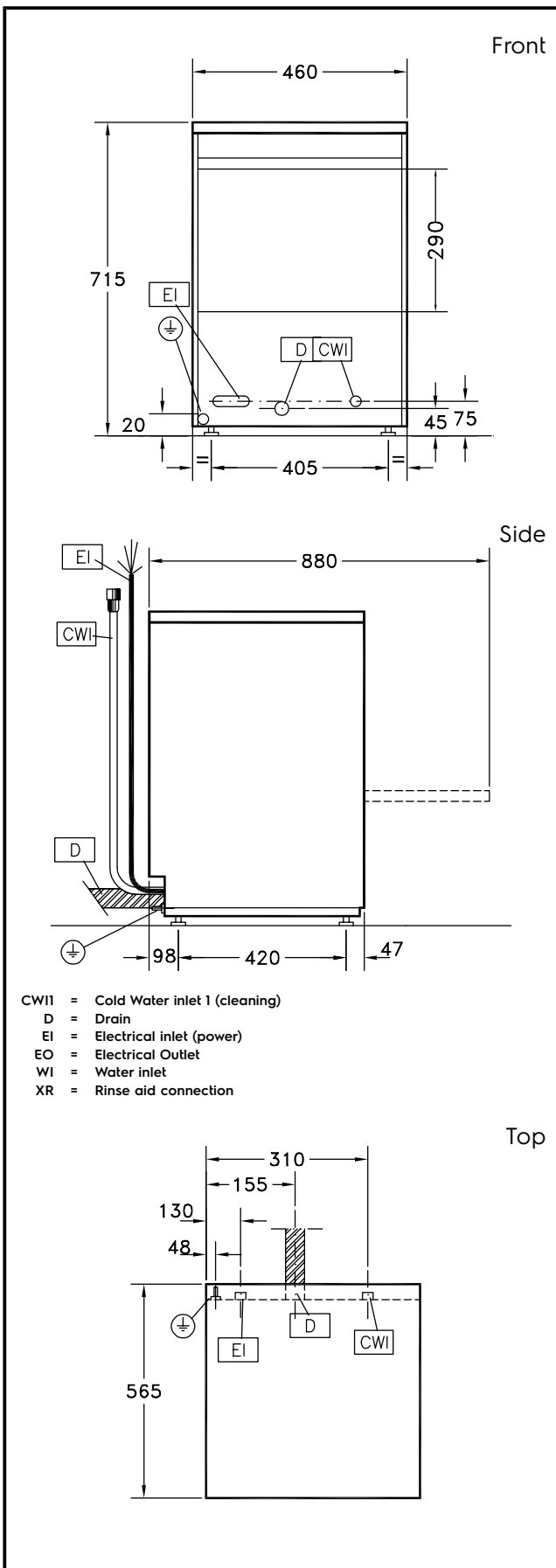
- 12lt external manual water softener PNC 860412
- 8lt external automatic water softener PNC 860413
- 20lt external manual water softener PNC 860430
- Kit to measure total and partial water hardness PNC 864050
- Rinse booster pump kit for single tank pressure dishwasher PNC 864051
- Yellow cutlery container PNC 864242
- Filter for total demineralization PNC 864367
- Pressure reducer for single tank dishwasher PNC 864461
- Drain pump kit for glasswasher electronic PNC 864465
- Kit detergent dispenser PNC 864469
- Cover rack for small and light items (500x500 baskets) PNC 867016
- Basket for glasses (395x395x115) PNC 867033
- Insert for 12 saucers, 290X90x75mm PNC 867048
- Basket for 16 plates diam.190 mm, 8 plates diam. 240 mm PNC 867052
- Basket for glasses (h 200 mm) PNC 867054
- Basket for glasses and saucers/ cutlery inserts PNC 867055
- Basket for glasses with angled base PNC 867056
- Round basket kit with square frame PNC 867057
- Insert for "flute" glasses PNC 867058
- Insert for 14 saucers PNC 867060
- Inclined insert for cups PNC 867061
- Insert for 7 plates d. 240mm PNC 867062



Electric

Supply voltage:	
402217 (ESICW)	220-240 V/1 ph/50 Hz
Default Installed Power:	3.3 kW
Boiler heating elements:	3 kW
Tank heating elements:	0,8 kW
Wash pump size:	0.3 kW

Water:

Pressure, bar min/max:	1.8-3 bar
Drain line size:	22mm
Washing tank capacity (lt):	6
Boiler Capacity (lt):	5
Incoming water line size:	G 3/4"

Key Information:

Baskets per hour*:	30
Working cycles time (sec.):	120/300/120
Wash temperature:	55-65°C
Cell dimensions - width:	400 mm
Cell dimensions - depth:	400 mm
Cell dimensions - height:	290 mm
Rinse temperature:	80-90 °C
External dimensions, Width:	460 mm
External dimensions, Depth:	565 mm
External dimensions, Height:	715 mm
Net weight:	37 kg
Shipping weight:	44 kg
Shipping height:	880 mm
Shipping width:	680 mm
Shipping depth:	520 mm
Shipping volume:	0.31 m ³

Sustainability

Water supply temperature*:	10-55 °C
Water consumption per cycle (lt):	2.3
Noise level:	69 dBA